

ATS30/50/100/150

The ATS is an accessory of the HPS. When both the grid and DG need to access the HPS, the ATS will be used to switch between the grid and DG automatically.

Features

-  HPS compatible
-  Flexible management
-  Transfer automatically between grid and DG
-  Support remote control of DG



Block Diagram

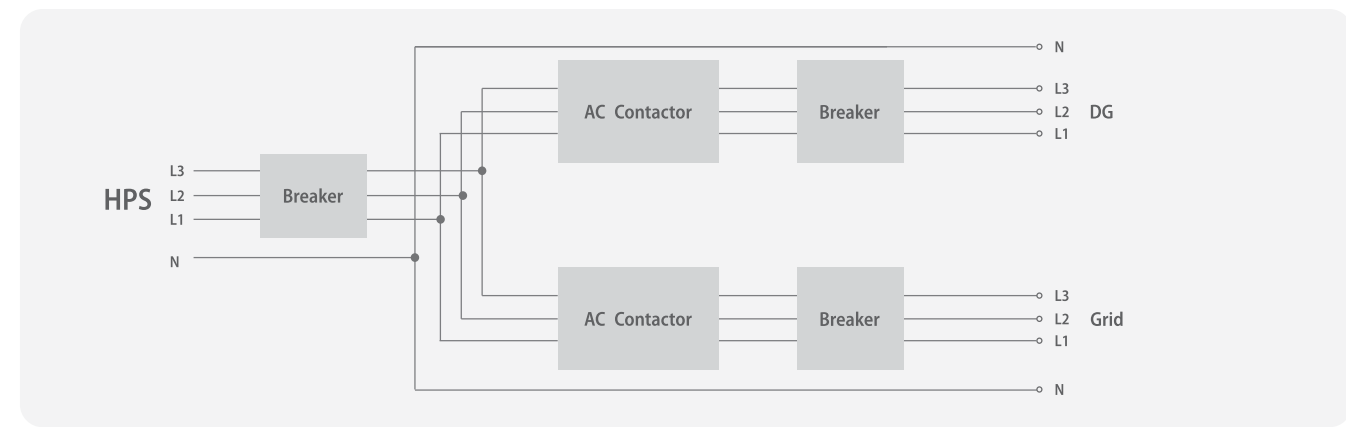

	ATS30	ATS50	ATS100	ATS150
Rated voltage	400V	400V	400V	400V
Rated current	86A	144A	288A	346A
Rated frequency	50/60Hz	50/60Hz	50/60Hz	50/60Hz
Rated power	60kVA	100kVA	200kVA	240kVA
Output breaker	100A	250A	400A	630A
Grid breaker	100A	250A	400A	630A
DG breaker	100A	250A	400A	630A
Lightning protection	Type II	Type II	Type II	Type II
Protection degree	IP20	IP20	IP20	IP20
Relative humidity	0~95% non-condensing	0~95% non-condensing	0~95% non-condensing	0~95% non-condensing
Operating temperature	-25°C~+55°C	-25°C~+55°C	-25°C~+55°C	-25°C~+55°C
Dimension (W/H/D)	600/1500/450mm	600/1500/450mm	700/1650/500mm	700/1650/500mm
Weight	75kg	77kg	125kg	125kg
Communication	RS485/CAN	RS485/CAN	RS485/CAN	RS485/CAN